

NEW

DRS61: Incremental encoders, number of lines and zero pulse width freely programmable

DRS60: Incremental Encoders with Zero-Pulse-Teach



Further highlights of this generation of encoders:

- Simple zero-pulse-teach by pressing a button located under a cap on the rear of the encoder
- Excellent price/performance ratio
- Long LED lifetime as a result of automatic light regulation
- Maximum reliability as a result of opto-ASICs with Chip-on-Board technology
- Interchangeable collets for hollow shaft diameters from 6 to 15 mm and 1/4, 3/8, 1/2 inch.

	Number of lines 1 up to 8,192
Incremental Encoder	

CoreTech[®]
by **SICK** | **STEGMANN**

Seltec Automation LLP
Unit G, Venture Business Park
Witty Street,
Hull.
East Yorkshire.
Tel. 01482 225297
Fax. 01482 212470
Web. www.seltec.co.uk

C

CoreTech technology permits tailor-made solutions for every application, due to its modular design.

With DRS61 incremental encoders, the number of lines from 1 to 8,192 and the width of the zero pulse can be freely programmed **by the customer**. Therefore, they will be of particular interest to end users, distributors, consulting engineers and system integrators.

DRS60 incremental encoders are available with any desired number of lines between 1 and 8,192.

Whether with face mount flange, servo flange, blind or through hollow shaft with connector or cable outlet, TTL or HTL interface – DRS60/61 encoders will meet virtually any application profile.

Thanks to this wide variety of products, there are numerous possible uses, for example in:

- machine tools
- textile machines
- woodworking machines
- packaging machines

SICK | **STEGMANN**

Number of lines
1 up to 8,192

Incremental Encoder

- Connector or cable outlet
- Protection class up to IP 66
- Electrical interfaces
TTL and HTL
- Zero-Pulse-Teach via
pressing a button
- DRS61: number of lines and
zero pulse width can be freely
programmed by the customer

Dimensional drawing servo flange radial

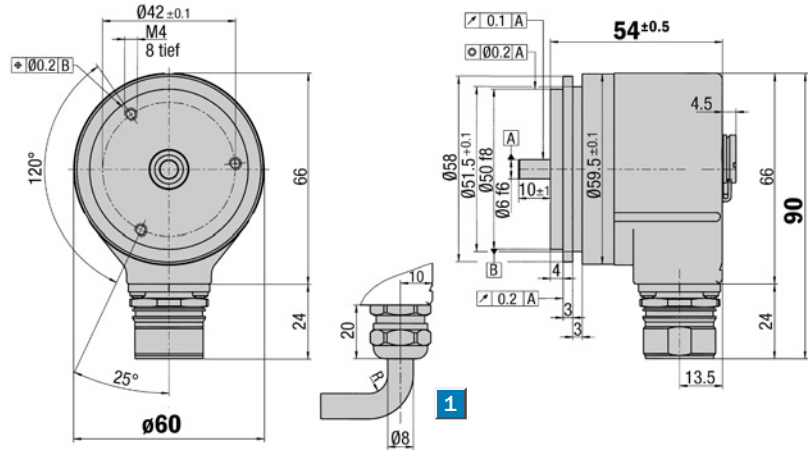

1 R = bending radius min. 40 mm

General tolerances according to DIN ISO 2768-mk

Dimensional drawing servo flange axial

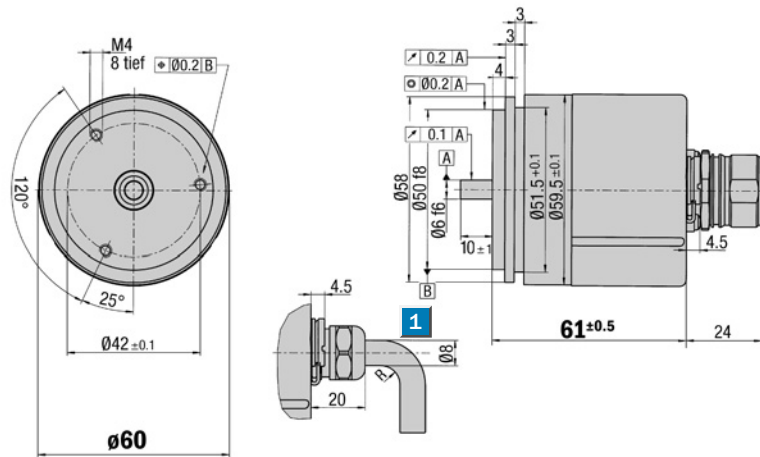

1 R = bending radius min. 40 mm

General tolerances according to DIN ISO 2768-mk

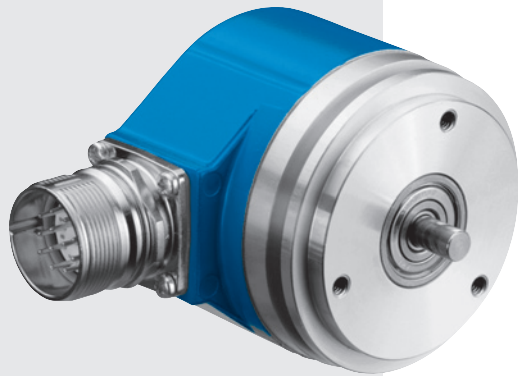

PIN and wire allocation/cable 11 core

PIN	Signal	Wire colour (Cable outlet)	Explanation
1	\bar{B}	black	Signal line
2	Sense +	grey	Connected internally to U_s
3	Z	lilac	Signal line
4	\bar{Z}	yellow	Signal line
5	A	white	Signal line
6	\bar{A}	brown	Signal line
7	N. C.	orange	Not connected
8	B	pink	Signal line
9	Screen		Housing potential
10	GND	blue	Zero volt connected to the encoder
11	Sense -	green	Connected internally to GND
12	U_s	red	Supply voltage ¹⁾

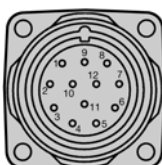

View of the connector M23 fitted to the encoder body

¹⁾ Potential free to housing
 N. C. =
 Not connected



Accessories

- Connection systems
- Mounting systems
- Programming Tool

Technical Data acc. to DIN 32878		DRS60/DRS61 servo flange	Flange type											
			servo											
Solid shaft	6 mm													
Number of lines per revolution	00001 up to 08192, see order info													
Electrical Interface	TTL/RS 422, 6-channel													
	HTL/push-pull, 6-channel													
Mass ¹⁾	Approx. 0.3 kg													
Moment of inertia of the rotor	48 gcm ²													
Measuring step	90°/number of lines													
Reference signal														
Number	1													
Position ²⁾	90° or 180°													
Error limits														
binary number of lines	0.035°													
non-binary number of lines	0.046°													
Measuring step deviation														
binary number of lines	0.005°													
non-binary number of lines	0.016°													
Max. output frequency														
TTL	820 kHz													
HTL	200 kHz													
Operating torque max.														
with shaft seal	6,000 min ⁻¹													
without shaft seal ³⁾	10,000 min ⁻¹													
Max. angular acceleration	5 x 10 ⁵ rad/s ²													
Operating torque	Typ. 0.2 Ncm													
Start up torque	Typ. 0.25 Ncm													
Permissible shaft loading														
radial	20 N													
axial	10 N													
Bearing lifetime	3.6 x 10 ⁹ revolutions													
Working temperature range	- 20 ... + 85 °C													
Storage temperature range	- 40 ... + 100 °C													
Permissible relative humidity ⁴⁾	90 %													
EMC ⁵⁾														
Resistance														
to shocks ⁶⁾	50/11 g/ms													
to vibration ⁷⁾	20/10 ... 2000 g/Hz													
Protection class IEC 60529														
Connector outlet ⁸⁾	IP 65													
Cable outlet	IP 66													
Operating voltage range														
Load current TTL/RS 422, 4.5 ... 5.5 V Max. 20 mA														
TTL/RS 422, 10 ... 32 V Max. 20 mA														
HTL/push-pull, 10 ... 32 V Max. 60 mA														
No-load operating current														
at 10 ... 32 V	Typ. 100 mA													
at 5 V	Typ. 120 mA													
Operation of zero-set ⁹⁾	≥ 100 ms													
Initialisation time after power on	40 ms													

¹⁾ Concerning encoder with connector

²⁾ Electrical, logically linked to A and B

³⁾ In case, that shaft seal has been removed by customer

⁴⁾ Condensation of the optical scanning not permitted

⁵⁾ To DIN EN 61000-6-2 and DIN EN 61000-6-3

⁶⁾ To DIN EN 60068-2-27

⁷⁾ To DIN EN 60068-2-6

⁸⁾ With mating connector fitted

⁹⁾ Only with shaft stationary

Number of lines
1 up to 8,192

Incremental Encoder

- Connector or cable outlet
- Protection class up to IP 66
- Electrical interfaces
TTL and HTL
- Zero-Pulse-Teach via pressing a button
- DRS61: number of lines and zero pulse width can be freely programmed by the customer

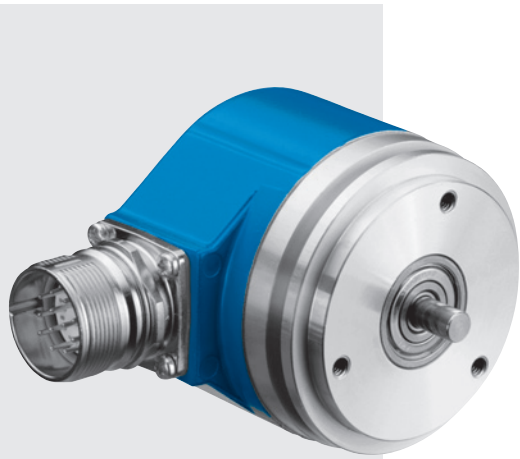

Incremental pulse diagram

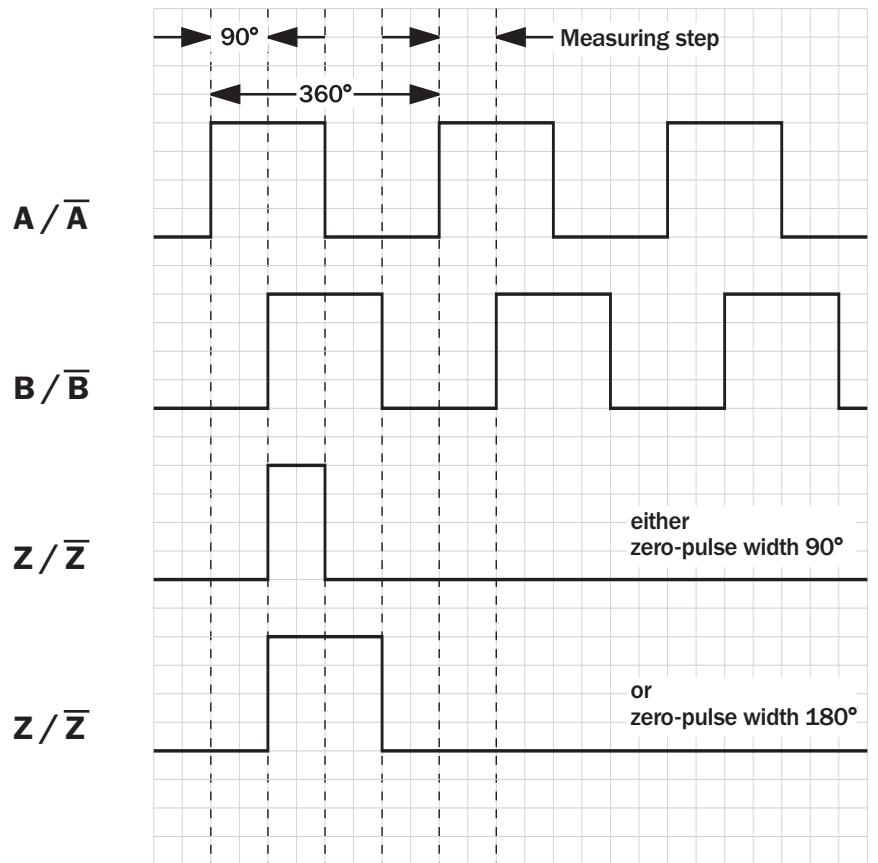

Electrical interface

Supply voltage	4.5 ... 5.5 V	10 ... 32 V	10 ... 32 V
Interfaces/drivers	TTL (RS 422)	TTL (RS 422)	HTL (push-pull)

Connection type

Cable radial	Cable axial	Connector radial	Connector axial
--------------	-------------	------------------	-----------------

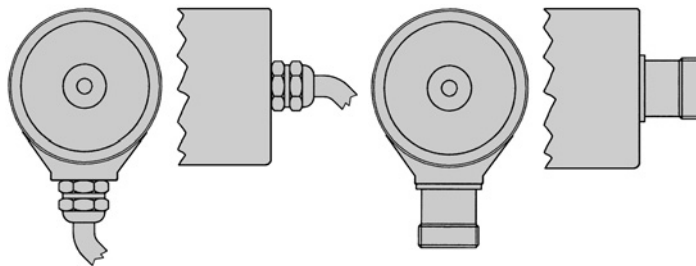

Accessories

Connection systems
Mounting systems
Programming Tool



Order information

Incremental Encoder DRS60, servo flange, solid shaft

Point 1	Point 2	Point 3	Point 4	Point 5	Point 6	Point 7	Point 8	Point 9	Point 10	Point 11	Point 12	Point 13	Point 14
D	R	S	6	0	-		1						

Electrical interface	
4.5 ... 5.5 V, TTL/RS 422 Zero-pulse width 90°	= A
4.5 ... 5.5 V, TTL/RS 422 Zero-pulse width 180°	= B
10 ... 32 V, TTL/RS 422 Zero-pulse width 90°	= C
10 ... 32 V, TTL/RS 422 Zero-pulse width 180°	= D
10 ... 32 V, HTL/push-pull Zero-pulse width 90°	= E
10 ... 32 V, HTL/push-pull Zero-pulse width 180°	= F

Mechanical interface
Servo flange, solid shaft 6 mm = 1

Connection type
Connector M23, 12 pin, radial = A
Connector M23, 12 pin, axial = B
Cable 11 core, radial 1.5 m = K
Cable 11 core, radial 3 m = L
Cable 11 core, radial 5 m = M
Cable 11 core, radial 10 m = N
Cable 11 core, axial 1.5 m = R
Cable 11 core, axial 3 m = S
Cable 11 core, axial 5 m = T
Cable 11 core, axial 10 m = U

Number of lines
Each number of lines from 00001 up to 08192 possible. Always 5 characters in clear text.

Order example Incremental Encoder DRS60

4.5 ... 5.5 V, TTL/RS 422 zero-pulse width 90°; servo flange; connector M23, 12 pin, radial; number of lines: 360

Point 1	Point 2	Point 3	Point 4	Point 5	Point 6	Point 7	Point 8	Point 9	Point 10	Point 11	Point 12	Point 13	Point 14
D	R	S	6	0	-	A	1	A	0	0	3	6	0



Incremental-Encoder DRS61, servo flange, solid shaft (number of lines and zero pulse width can be freely programmed by the customer) ¹

Point 1	Point 2	Point 3	Point 4	Point 5	Point 6	Point 7	Point 8	Point 9	Point 10	Point 11	Point 12	Point 13	Point 14
D	R	S	6	1	-		1		0	8	1	9	2

Electrical interface	
4.5 ... 5.5 V, TTL/RS 422	= A
10 ... 32 V, TTL/RS 422	= C
10 ... 32 V, HTL/push-pull	= E

Mechanical interface
Servo flange, solid shaft 6 mm = 1

Connection type
Connector M23, 12 pin, radial = A
Connector M23, 12 pin, axial = B
Cable 11 core, radial 1.5 m = K
Cable 11 core, axial 1.5 m = R

Number of lines
Factory-programmed to 8,192.

Order example Incremental Encoder DRS61

4.5 ... 5.5 Volt, TTL/RS 422; servo flange; connector M23, 12 pin, radial; number of lines: 8,192 (factory-programmed)

Point 1	Point 2	Point 3	Point 4	Point 5	Point 6	Point 7	Point 8	Point 9	Point 10	Point 11	Point 12	Point 13	Point 14
D	R	S	6	1	-	A	1	A	0	8	1	9	2

¹ Please order programming tool separately (see accessories page 18)